

# LP4 62

## USER MANUAL

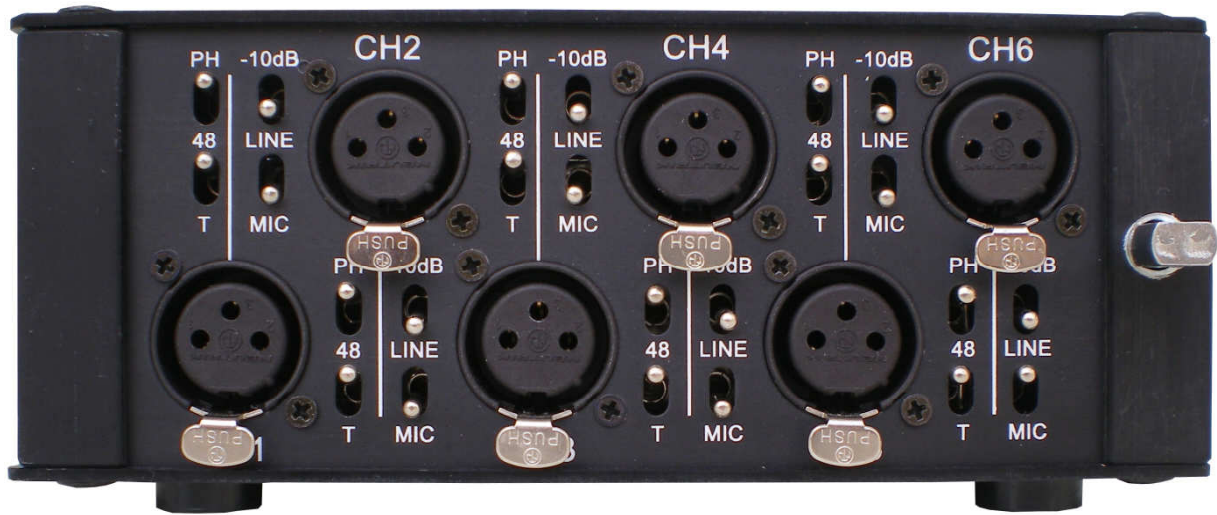

TW LP4 62 (Location Production) stereo microphone mixer is a compact portable six-channel unit designed for electronic news gathering (ENG) quality sound mixing in a motion picture or television film.



## LEFT SIDE PANEL

- **Balanced channel inputs** – six electronically balanced circuits (transformer balanced is optional) in phase with one another. XLR connectors should be wired as pin1 ground, pin2 +phase signal and pin3 –phase signal.
- **Microphone powering selector switches** – The input sensitivity - when Phantom switch off – is 0.2mV and no power. Selected 48, or T, mic powering, 10 dB of attenuation is automatically introduced, considering the sensitivity of condenser mics.
- **Phantom on / off switch** – The current consumption of the phantom power supply is 13 mA. Phantom power supply may be switched off (only if using dynamic, wireless or T powering mics) to increase the lifespan of the internal batteries between two chargings.
- **Attenuation switches** – The gain of the mic preamplifiers may be decreased by –10 dB
- **Mic / line level switches** – Selects mic or line to add –60 dB attenuation before the mic preamplifiers.



## FRONT PANEL

- **Modulometers** – Continuous lighting, peak reading, BBC 1-7, dB or VU scaling, built-in red LEDs indicate when the gain reduction is occurring with the limiters switched on.
- **Battery check pushbutton**
- **6.3mm phone jacks**
- **Monitor selector switch** – ST stereo. L+R sum signals, phase check, MS stereo equivalent Left. L–R difference signals MS stereo equivalent Right. MS matrix, MS stereo equivalent. R right channel. L left channel.
- **Phones volume control** – Output voltage into 50  $\Omega$  adjustable from 20 to 500 mV.
- **Limiters on / off / link switch** – The limiters have fast attack time (less than 1 msec) and a slow release time to smooth operation. Two red LEDs are built in the meters to indicate when the limiters are selected and gain reduction is occurring. Threshold is internally set to +6 dBu at the balanced output. To adjust the threshold for a value different from the supplied +6 dBu, see page ADJUSTMENT POINTS.
- **Tone reference generator switch** – 1 kHz sine wave signal is fed to both left and right outputs, its level can be controlled by the Master control.
- **Slate microphone** – It can be used either for identifying recorded segments or as an emergency field microphone.
- **Low-cut filter switches** – Low frequency attenuation is 14 dB / octave at 80 and 160 Hz.
- **Pan switches** – Assign selected input signal to Left or Right output. In M position, equal amount of signal is sent to Left and Right outputs. The S position of Pan switches 1 assigns Channels 1–2 as stereo pairs controlled by Channel 1 Faders respectively.
- **Channel gain controls**
- **Pre-Fade Listen rotary switch** – Each channel can be checked by monitoring. Output audio signal is not interrupted when the PFL pushbutton is activated.
- **EE / RTN12 switch** – A two-position switch selects the direct outputs from the mixer or the return 1 and 2 as a signal source for the monitoring.
- **Master** – The fader sets the gain of both Left and Right legs and has +6 dB of gain in hand with the nominal 0 dB gain position marked.
- **PWR LED** – A red LED lights to indicate power is on. Flashes when voltage is 11.5 Vdc or less.
- **Power switch** – In position EXT the mixer will be powered by an external DC supply and in BATT by the internal batteries. Batteries should be recharged with the switch in EXT position.



## RIGHT SIDE PANEL

• **Balanced outputs** – The main outputs are via transformer balanced XLR connectors and a Hirose 10pin multiway connector is also fitted to facilitate rapid connection of outputs and monitor returns. The line level is set on 600  $\Omega$  at 0 dBu and +4 dBu for VU metered mixers. The Hirose 10pin connector is wired as follows:

	pin 9-10. GROUND
pin 1. + LEFT output	pin 5. RIGHT return
pin 2. – LEFT output	pin 6. N / C
pin 3. +RIGHT output	pin 7. LEFT return
pin 4. –RIGHT output	pin 8. N / C

• **Unbalanced output** – 5pin TA5F connector carries an unbalanced stereo output signal – at a level 3 dB lower than balanced outputs – to feed a recorder, DAT, etc. and monitor returns. The XLR 5pin connector is wired as follows:

	pin 1. GROUND
pin 2. LEFT output	pin 4. LEFT return
pin 3. RIGHT output	pin 5. RIGHT return

• **Channel Direct Outputs** – 7 pin XLR connector carries unbalanced direct outputs. Signal is prefader at a level – 20dBu to feed a recorder and monitor returns with 3.5 jack. 7pin connector wired,

	pin 7. GROUND
pin 1. CH1 direct output	pin 4. CH4 direct output
pin 2. CH2 direct output	pin 5. CH5 direct output
pin 3. CH3 direct output	pin 6. CH6 direct output

• **Line / mic level switch** – The line level at XLR and Hirose connectors can be attenuated by 50 dB to provide the microphone level.

• **3.5 mm stereo monitor input jack**

• **Return 1 or 2 selector switch** – In position RTN1 the 3.5 jack and Hirose returns are chosen for monitor, switched to RTN2 the returns of XLR7 will be fitted by the monitoring circuits.

• **Power supply** – The DC power stabiliser of TW mixer has built-in Poly-Fuse to protect the unit. If a problem occurs that trips this fuse, it will reset after the power supply is disconnected for about 15 seconds. The mixer may be powered by 12 pieces internal AA size rechargeable batteries or an external DC supply 12-24 Vdc. Fully charged batteries will typically power the mixer for 8 hours at continuous use. The external XLR 4pin connector is wired as follows:

pin 1., 2. GROUND	pin 3. Battery Charge	pin 4. External 12-24 Vdc
-------------------	-----------------------	---------------------------

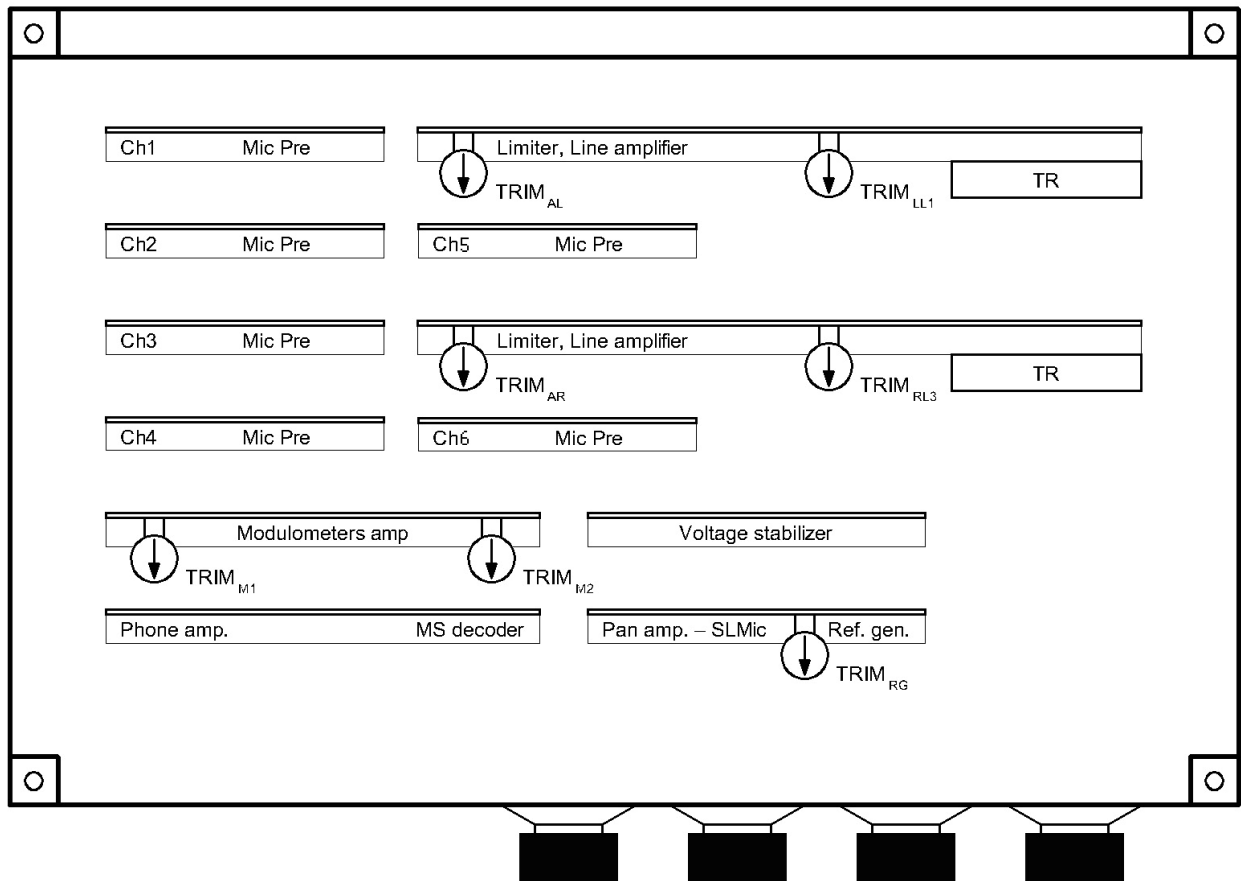

## ADJUSTMENT POINTS

- Gain and modulometer adjustment** – Connect an AC voltmeter to the Left balanced line output. Set channel 1 pan switch to L position, turn channel 1 fader fully clockwise, Master potentiometer in 0 dB position and switch LFA off. Connect an audio generator 1 kHz 0 dBm attenuator  $-80$  dB to Mic 1 Input and adjust  $TRIM_{AL}$  in the Left Limiter amplifier to obtain 0 dBu (+4 dBu on VU metered mixers) at the Left balanced output. Then adjust  $TRIM_{M1}$  in the Left Modulometer amplifier board to obtain 0 dB on the Left meter. Cut off the input signal and switch on the Reference Generator . Adjust  $TRIM_{RG}$  to obtain 0 dB on the Left modulometer. Repeat for Right output and Right modulometer.
- Limiter threshold adjustment** – Connect an AC voltmeter to the Left balanced line output. Apply a 1 kHz signal until the AC voltmeter reading is at the level desired with limiter switched off. Switch on the limiter and adjust  $TRIM_{LL1}$  in Left limiter amplifier until the level drops 0.5 dB. Repeat for Right output and Right limiter trimpot.

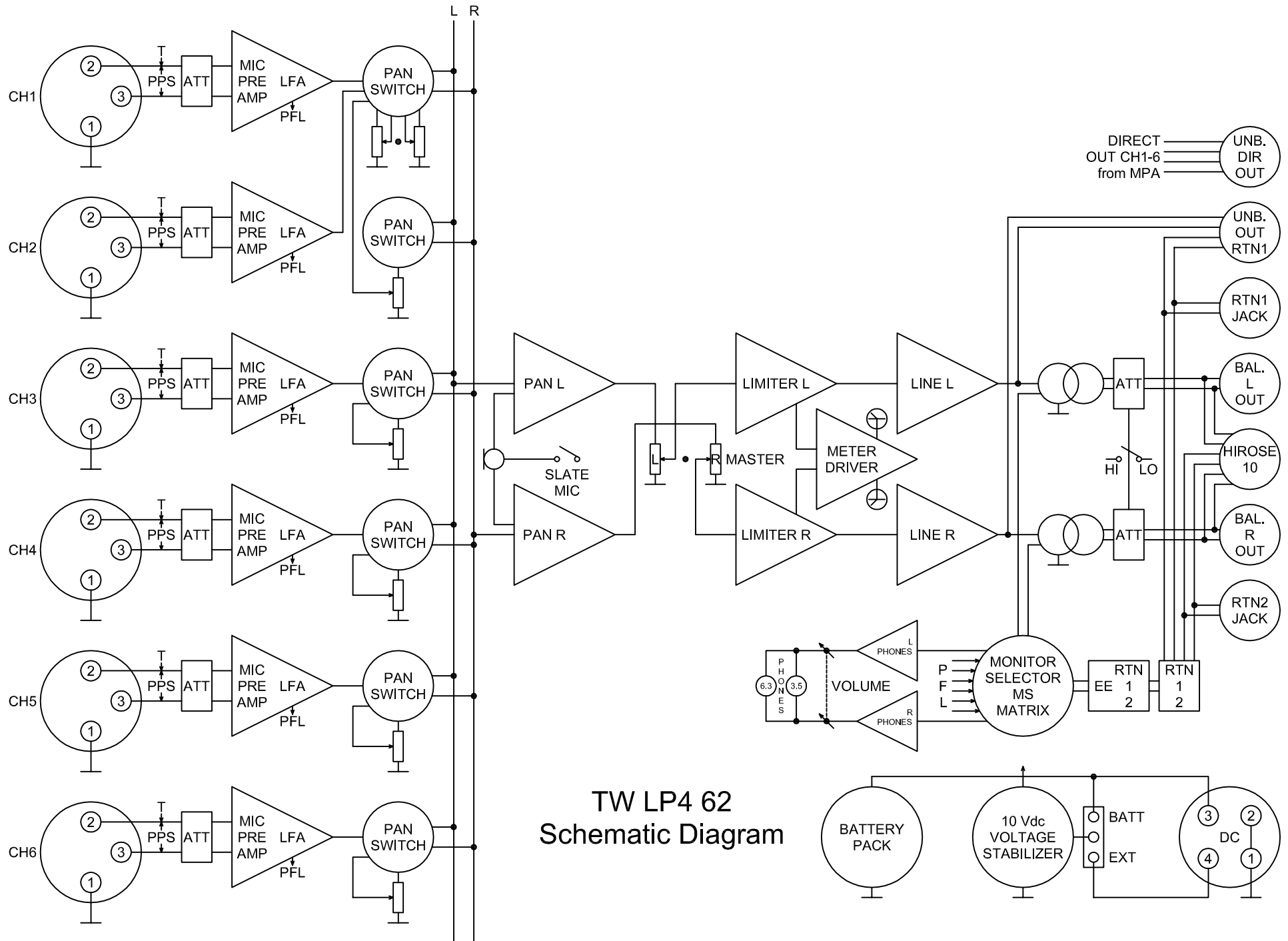

TW LP4 62  
Schematic Diagram

## SPECIFICATIONS

### • Inputs

Microphone: six transformerless XLR female  
Sensitivity: -75 dBu  
Maximum input level: -20 dBu  
Microphone power: 48 V, T (DIN AB)  
Line attenuation: adds 60 dB attenuation before the mic preamp.  
Signal to Noise ratio: > 65 dB, Equivalent Input Noise: -125 dBu  
Frequency response: 20 Hz - 20 kHz  $\pm 2$  dB  
Harmonic distortion: less than 0.2 %  
Low-cut filter: 80/100 Hz / 14 dB octave  
Crosstalk isolation, channel to channel: < -65 dB

### • Outputs

Line: transformer balanced XLR  
Line level on 600  $\Omega$  0 dB on the modulometer: 0 dBu  
4 on the 1-7 scaling: 0 dBu  
0 Vu on the VU scaling: +4 dBu  
Four Direct Unbalanced outputs : -20 dBu  
Maximum output level: +18 dBu

- Internal power: 12 AA size rechargeable batteries
- External power: 11-25 Vdc
- Power consumption: 99 mA
- Dimensions: 255 x 165 x 65 mm (10 x 6.5 x 2.6 in)
- Weight: 2 kg (4.2 lbs)

TWELCO

ELECTRONIC COMPONENTS

Kaptárkő u. 11.  
Budapest H-1118  
HUNGARY

tel.: +36 1 2466549  
fax: +36 1 2480194  
e-mail: [twelco@upcmail.hu](mailto:twelco@upcmail.hu)  
[www.twelco.hu](http://www.twelco.hu)